

Drives

Low Voltage

Energy efficiency
for every situation.



Boost your
productivity
and energy
efficiency

Since 1987
 offering solutions
 for industrial
 automation
 processes.

+20 International
 subsidiaries

+1_M

OF INSTALLED EQUIPMENT

+50_{MW}

SOLAR PUMPING INSTALLATIONS

+50

COUNTRIES

SD300

For harsh environments. Protected against fire dust and high pressure water jets.

SD300

The SD300 is a high-performance variable-speed drive designed for general use. It excels in demanding high-load applications that require high starting torque and accurate control.

Energy saving. Reduces motor power consumption under light load conditions.

- Ideal for variable torque applications.
- Power consumption reduction depending on motor load.
- Reduction of motor losses.
- Automatic and manual adjustment.

Internal PLC. PLC functions to simplify your external control requirements.

- Simple and powerful functionality.
- Logic operations.
- Arithmetic operations.
- Comparators.
- Scan rate selection.
- Sequential execution.

Pump control. Smooth and easy control for pumps in simple applications.

- Process PID controller.
- Pre-PID functionality.
- Sleep mode.
- Second PID adjustment.
- Engineering units.

Sensorless vector control. Exceptional performance for asynchronous and synchronous motors.

- Control of asynchronous and synchronous (PMSM) motors.
- Smooth and dynamic control of the motor.
- 200% torque at 0,5Hz.
- Static auto-tuning.
- Fast response to transient load torque changes.
- Improved motor regeneration control.
- Dynamic motor flux control.

For every need. Suitable with all standard machine and process control needs as pumps, fans, conveyors, compressors, food & beverage, materials handling, packaging, wood processing, plastics, automatic doors or any general purpose machinery.

Multiple fieldbus options. The SD300 integrates the most powerful and widely used fieldbus communication protocols used in automation and industry today. The multiple fieldbus options add another dimension to the versatility of the drive and allow the full potential of the SD300 to be realised as a key component in the automation and control network (Profibus, Profinet, Ethercat, Ethernet I/P, Modbus TCP).



SD300 IP20

230 - 480 V

From 0.4 kW to 90 kW

LCD display integrated
in the drives from 30kW

150% overload capacity
at 50°C

Output frequency up
to 400Hz

Integrated EMC filter

High torque at very low
speed (200% at 0,5Hz)



SD300

IP66



230 - 480 V

From 0.4 kW to 22 kW

150% overload capacity
at 50°C

Output frequency up
to 400Hz

Integrated EMC filter

High torque at very low
speed (200% at 0,5Hz)

SD300

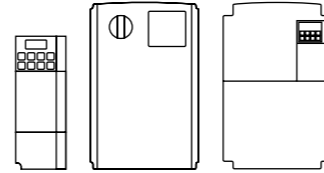

INPUT	Power ranges	0.4kW - 2.2kW 230V - Single Phase 0.4kW - 22kW 230V - 3-Phase 0.4kW - 90kW 400V - 3-Phase	
	Voltage range	230V: 200-240V Single Phase/3-Phase (-15%/+10%) 400V: 380-480V 3-Phase (-15%/+10%)	
	EMC Filter	C2: 240Vac C3: 240Vac-400Vac	
OUTPUT	Control method	V/f, Slip compensation, Sensorless vector, PMSM VC ^[1]	
	Frequency setting resolution	Digital command: 0.01Hz / Analog command: 0.06Hz (maximum frequency: 60Hz)	
	Frequency accuracy	1% of the maximum output frequency	
	V/F pattern	Linear, Quadratic, User V/F	
	Overload capacity	150% for 60 sec. (Heavy duty) 120% for 60 sec. (Normal duty) ^[2] 200% for 3 sec. (Heavy duty)	
	Output frequency	0-400Hz (Sensorless: 0-120Hz)	
	Torque boost	Manual/Automatic torque boost	
OPERATION	Operation mode	Keypad / Terminal / Communication option selectable	
	Frequency setting	Analog : -10~10V, 0~10V, 4~20mA / Digital : Keypad, Pulse train input	
	Operation function	PID control, 3-wire operation, Frequency limit, Second function, Anti-forward and reverse direction rotation, Speed search, Power braking, Leakage reduction, Up-down operation, DC braking, Frequency jump, Slip compensation, Automatic restart, Automatic tuning, Energy buffering, Flux braking, Fire Mode	
		NPN (Sink) / PNP (Source) selectable	
	Input	Multi-function Terminal IP66 degree: 5 inputs IP20 degree: 7 inputs	Function: Forward run, Reverse run, Reset, External trip, Emergency stop, Jog operation, Multi-step frequency-high, middle, low, Multi-step acceleration/ deceleration-high, middle, low, DC braking at stop, 2 nd motor select, Frequency up/down, 3-wire operation, Change into normal operation during PID operation, Change into main body operation during option operation, Analog command frequency fixing, Acceleration/deceleration stop etc. Selectable
		Analog input	V1: -10~10V, selectable V2: 0~10V/12 4~20mA
		Pulse train	0~32kHz, Low level: 0~2.5V, High level: 3.5~12V
	Output	Open collector terminal	Fault output and drive operation less than DC 24V 50mA
		Multi-function relay	status output (N.O., N.C.) less than AC 250V 1A, less than DC 30V 1A
		Analog output	Selectable 0~12Vdc/0~24mA Frequency, Output current, Output voltage, DC bus voltage etc. selectable
	Pulse train	Maximum 32kHz, 10~12V	
PROTECTIVE FUNCTION	Trip	Over current trip, External signal trip, ARM short circuit current trip, Over heat trip, Ground trip, Motor over heat trip, I/O board link trip, No motor trip, Parameter writing trip, Emergency stop trip, Command loss trip, External memory error, CPU watchdog trip, Motor normal load trip, Over voltage trip, Temperature sensor trip, Drive over heat, Option trip, Output imaging trip, Drive overload trip, Fan trip, Pre-PID operation failure, External break trip, Low voltage trip during operation, Low voltage trip, Safety A(B) trip, Analog input error, Motor overload trip	
	Alarm	Command loss trip alarm, overload alarm, normal load alarm, drive overload alarm, fan operation alarm, resistance braking rate alarm, number of corrections on rotor tuning error	
	Momentary power loss	HD below 15ms (ND below 8ms): Continuous operation (To be within rated input voltage, rated output) HD above 15ms (ND above 8ms): Automatic restart operation enable	

NOTES

ENVIRONMENT	Cooling type	Forced fan cooling structure
	Protection degree	IP20/UL Open (Default), UL Enclosed Type 1 (Option), IP66/NEMA 4X (Option)
	Ambient temperature	IP20: HD: -10~50°C(14~122°F) ND: -10~40°C(14~104°F) [However, recommended to use load below 80% when using at 50°C under light load]
		IP66: HD: -10~40°C(14~104°F)
	Storage temperature	-20~65°C (-4~149°F)
	Humidity	Relative humidity below 90% RH (non condensing)
	Altitude, vibration	Below 1000m, below 9.8m/sec ² (1G)
	Location	No corrosive gas, flammable gas, oil mist and dust etc. indoors (Pollution Degree 3 Env.)
	Pressure	70~106 kPa
REGULATIONS	Global certification	CE, UL, cUL, RoHS
	PCB	3C2 Conformal coating

NOTES

- [1] Please consult Power Electronics before the installation with these kind of motors.
[2] Only available with IP20 protection degree.

SD300

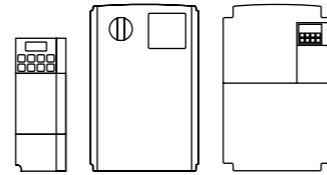

INPUT & OUTPUT TERMINATIONS

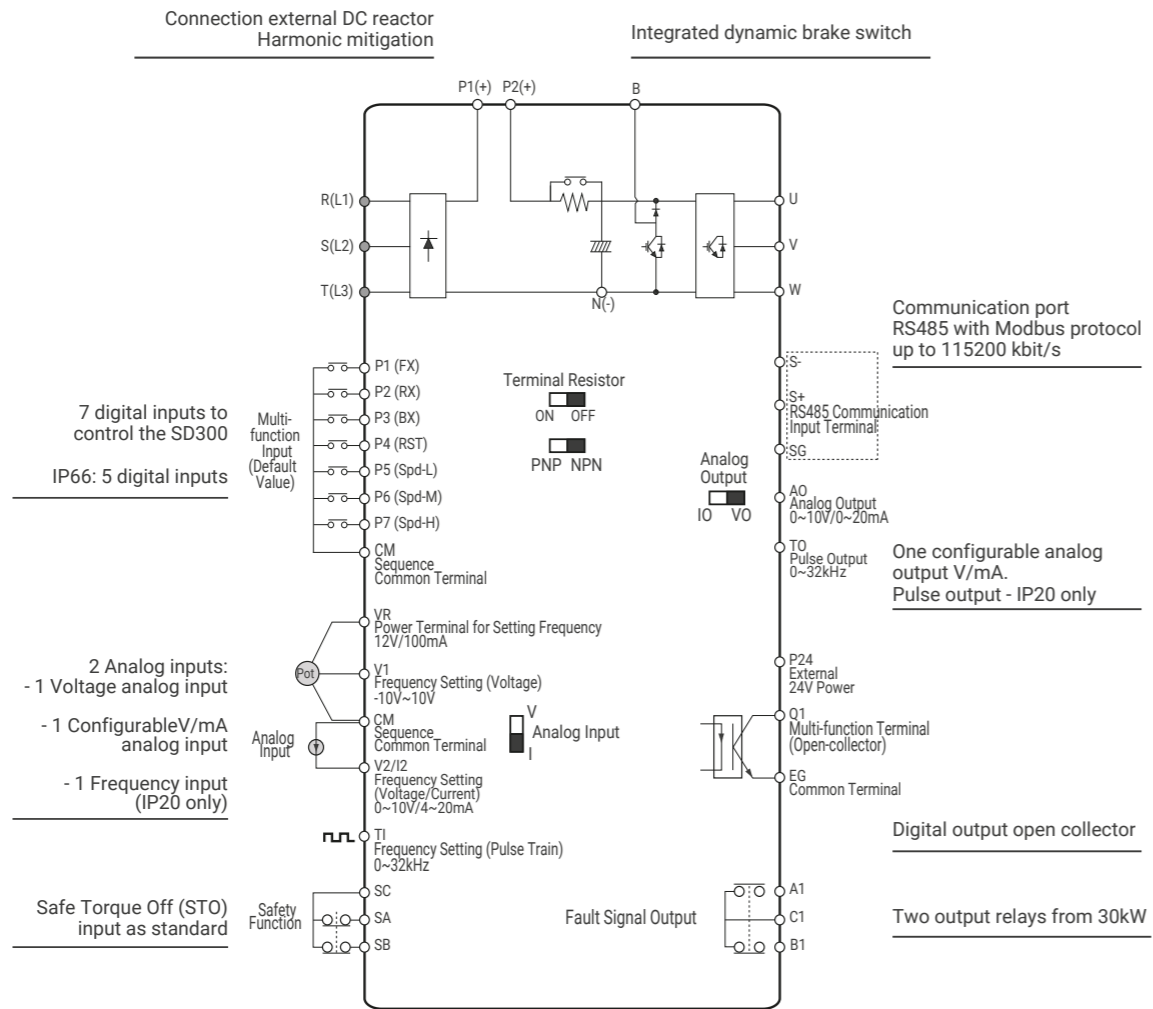

FRAMES IP20

Frame 1F

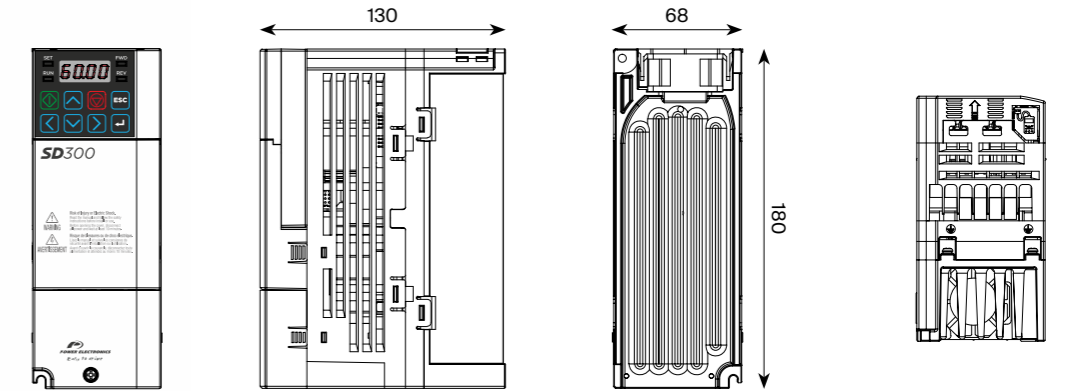

Frame 2F

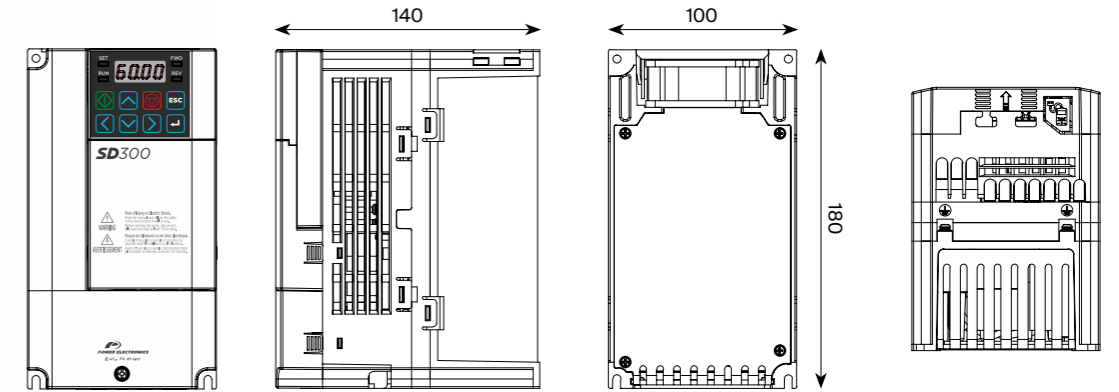

Frame 3F

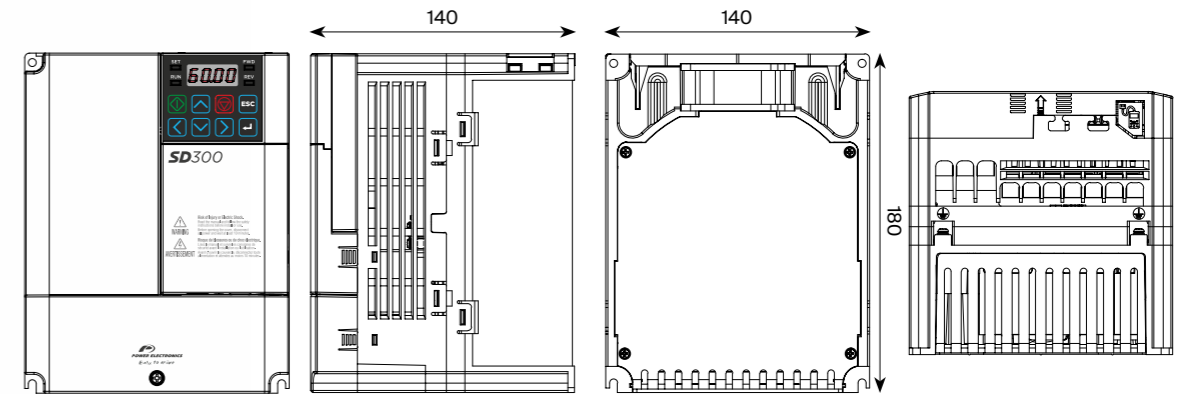

FRONT

SIDE

BACK

BOTTOM

SD300

FRAMES
IP20

Frame 4

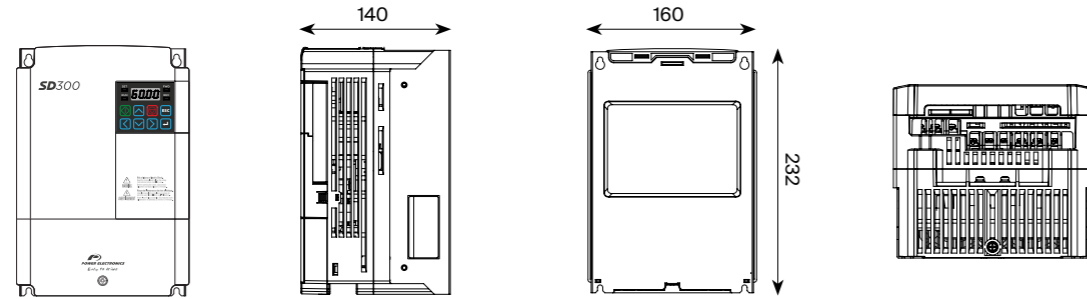

Frame 5

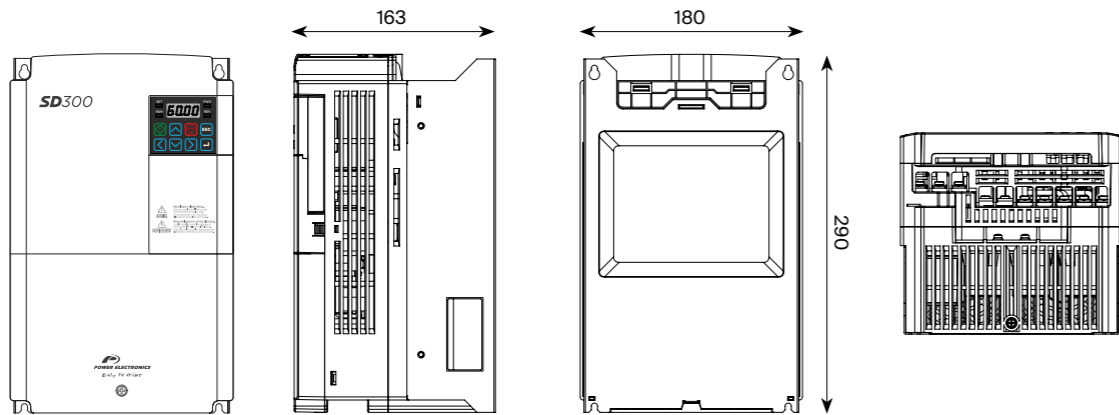

Frame 6

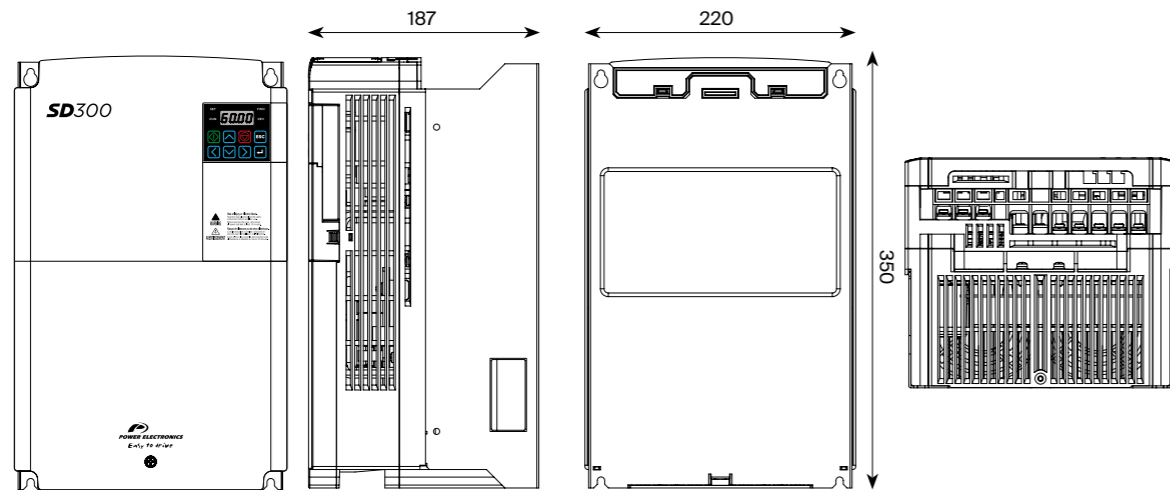

FRONT

SIDE

BACK

BOTTOM

FRAMES

IP20 Frame 7

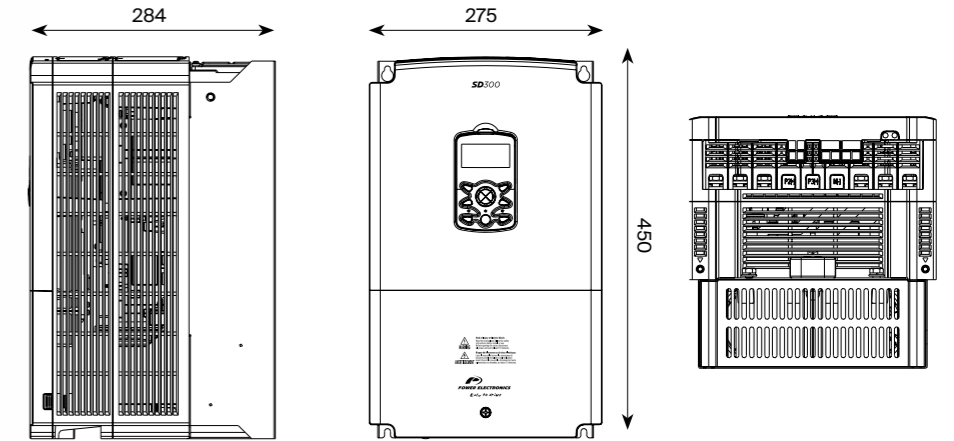

Frame 8

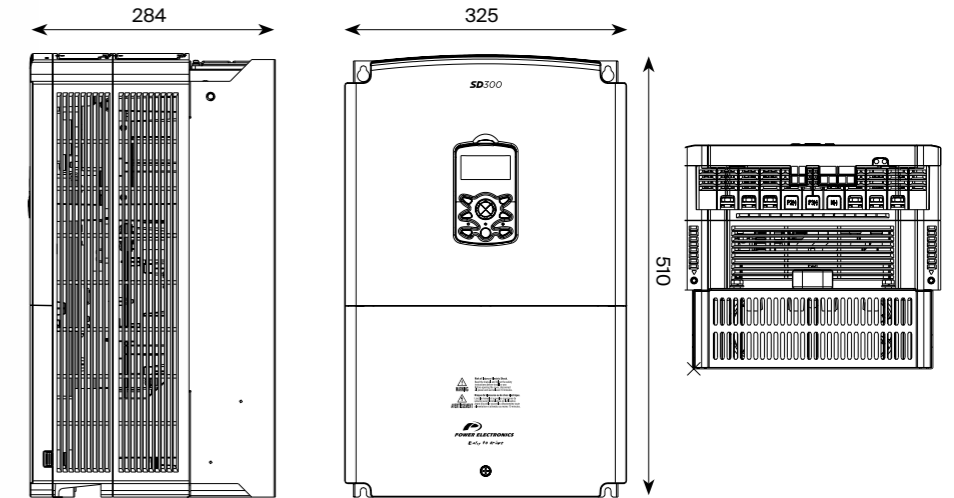

Frame 9

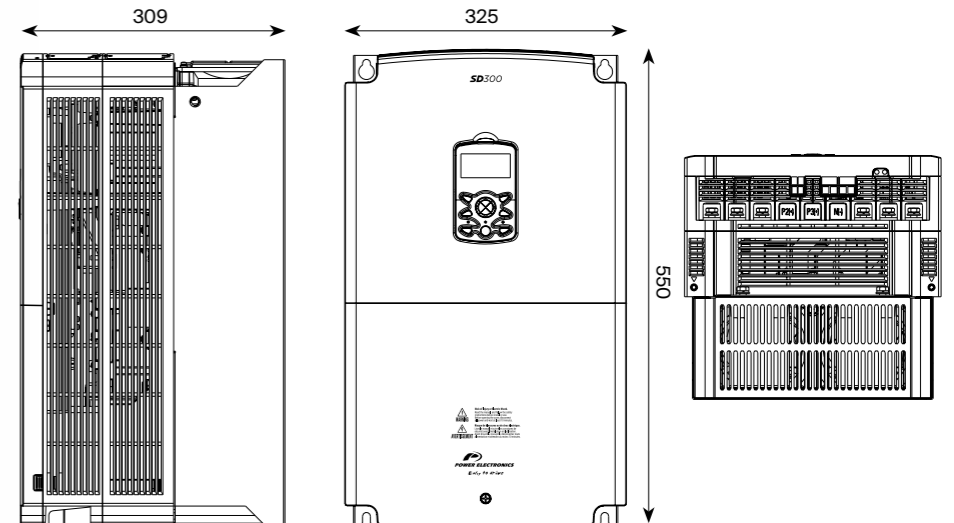

SIDE

BACK

BOTTOM

SD300

FRAMES - IP66
NEMA 4X

Frame 1l

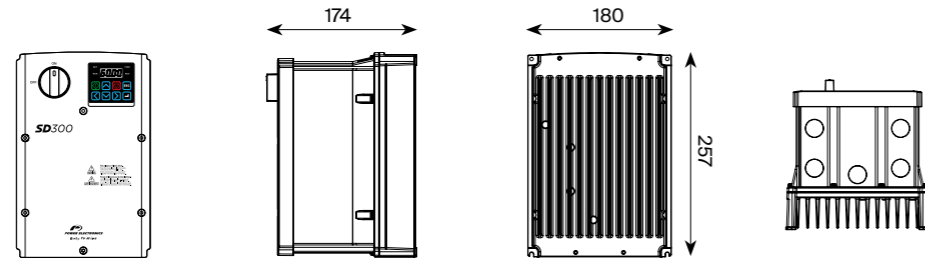

Frame 2l

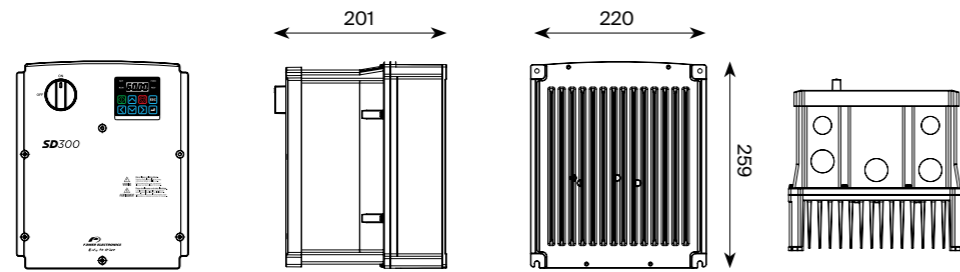

Frame 3l

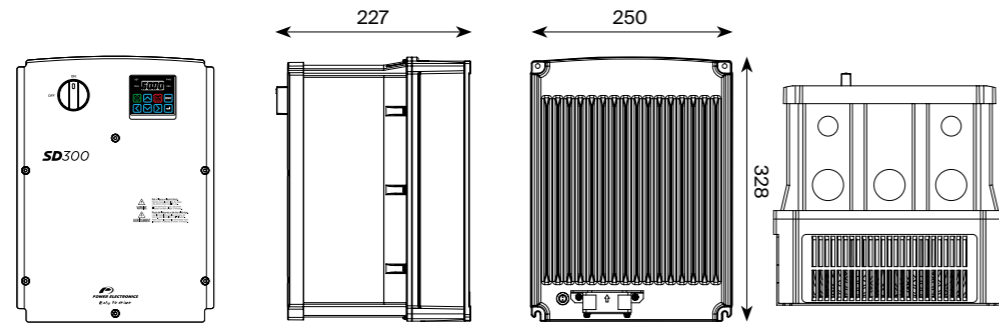

FRONT

SIDE

BACK

BOTTOM

FRAMES - IP66
NEMA 4X

Frame 4l

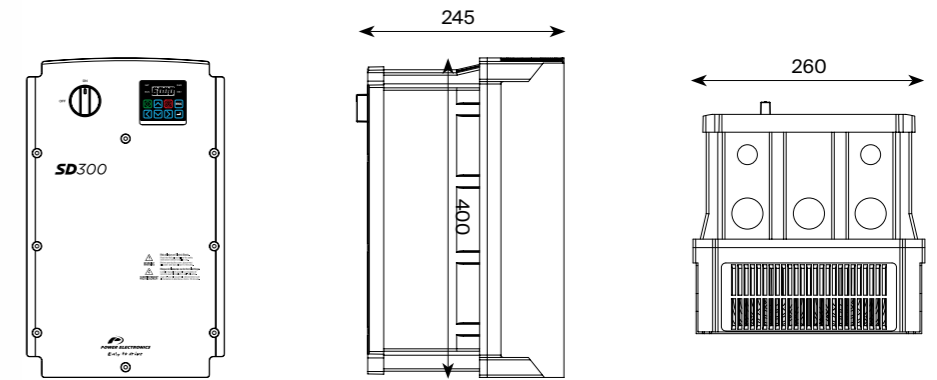

Frame 5l

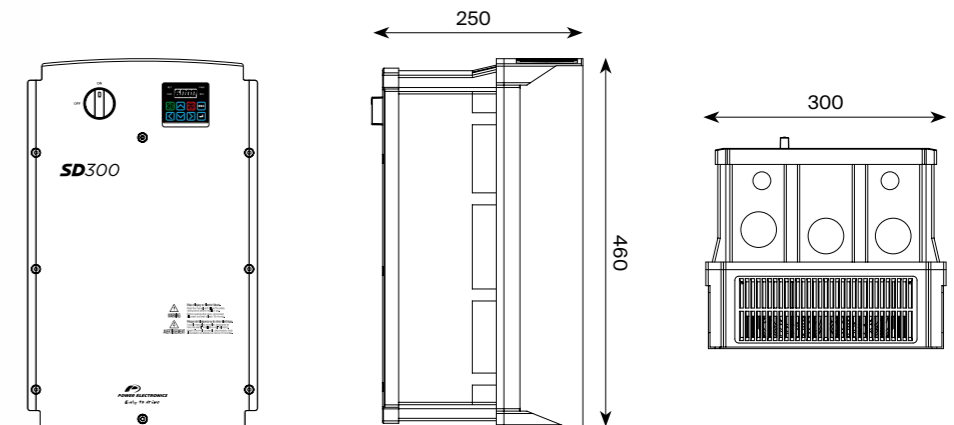

FRONT

SIDE

BOTTOM

SD300

CONFIGURATION TABLE & STANDARD RATINGS

SD3	058		04		20		--		--	
SD300 SERIES	Current normal duty*		Voltage		Degree of protection		EMC Filter		Isolator	
SD3	002	2A	1	230Vac Single Phase	2	IP20	F	Extended	-	Standard
	...		2	230Vac Three Phase	6	IP66	-	Standard	N	Not Included
	069	69A	4	400Vac Three Phase						

*Heavy duty for IP66 models.

230 VAC SINGLE PHASE

230VAC SINGLE PHASE - IP20															
Power ND (kW)	Current ND (A)	Power HD (kW)	Current HD (A)	EMC STANDARD						EMC EXTENDED					
				MODEL	WEIGHT (kg)	DIMENSIONS (mm)			FRAME	MODEL	WEIGHT (kg)	DIMENSIONS (mm)			FRAME
						W	H	D				W	H	D	
0,75	3.1	0,4	2.5	SD300312	0.88	68	128	128	2N	SD300312F ^[1]	1.1	68	180	130	1F
1,5	6.0	0,75	5.0	SD300612	1.3	100	128	130	3N	SD300612F ^[1]	1.8	100	180	140	2F
2,2	9.6	1,5	8.0	SD300912	1.5	100	128	145	4N	SD300912F ^[1]	2.2	140	180	140	3F
3,7	12.0	2,2	11.0	SD301212	2.2	140	128	145	5N	SD301212F ^[1]	2.2	140	180	140	3F

230 VAC THREE PHASE

230VAC THREE PHASE - IP20										
Power ND (kW)	Current ND (A)	Power HD (kW)	Current HD (A)	MODEL	WEIGHT (kg)	DIMENSIONS (mm)			FRAME	
						W	H	D		
0,75	3.1	0,4	2.5	SD300322	0.86	68	128	123	1F	
1,5	6.0	0,75	5.0	SD300622	0.86	68	128	128	2F	
2,2	9.6	1,5	8.0	SD300922	1.5	100	128	130	3F	
4	12	2,2	11	SD301222	1.5	100	128	145	4	
5,5	18	4	17	SD301822	2.3	140	128	145	5	
7,5	30	5,5	24	SD303022	3.3	160	232	140	4	
11	40	7,5	32	SD304022	3.3	160	232	140	4	
15	56	11	46	SD305622	4.6	180	290	163	5	
22	69	15	60	SD306922	5.5	220	350	187	6	

NOTES

400 VAC THREE PHASE

400VAC THREE PHASE - IP20 - EMC EXTENDED										
Power ND (kW)	Current ND (A)	Power HD (kW)	Current HD (A)	MODEL	WEIGHT (kg)	DIMENSIONS (mm)			FRAME	
						W	H	D		
0,75	2.0	0,4	1.3	SD300242F ^[2]	1.1	68	180	130	1F	
1,5	3.1	0,75	2.4	SD300342F ^[2]	1.2	68	180	130	1F	
2,2	5.1	1,5	4.0	SD300542F ^[2]	1.8	100	180	140	2F	
4	10	2,2	8	SD300742F ^[2]	1.8	100	180	140	2F	
5,5	10	4	9	SD301042F ^[2]	2.9	140	180	140	3F	
7,5	16	5,5	12	SD301642F ^[2]	3.4	160	232	140	4	
11	23	7,5	16	SD302342F ^[2]	3.4	160	232	140	4	
15	30	11	24	SD303042F ^[2]	4.8	180	290	163	5	
18,5	38	15	30	SD303842F ^[2]	4.8	180	290	163	5	
22	44	18,5	39	SD304442F ^[2]	7.5	220	350	187	6	
30	58	22	45	SD305842F ^[2]	7.5	220	350	187	6	
37	75	30	61	SD307542F ^[2]	26	450	275	284	7	
45	91	37	75	SD309042F ^[2]	35	510	325	309	8	
55	107	45	91	SD310542F ^[2]	35	510	325	309	8	
75	142	55	110	SD314042F ^[2]	43	550	325	309	9	
90	169	75	152	SD317042F ^[2]	43	550	325	309	9	

400VAC THREE PHASE - IP66 (only Heavy Duty)							
Power HD (kW)	Current HD (A)	EMC EXTENDED		DIMENSIONS (mm)			FRAME
		MODEL	WEIGHT (kg)	W	H	D	
0,4	1.3	SD300146F ^[2]	3.7	180	257	174	1I
0,75	2.4	SD300246F ^[2]	3.7	180	257	174	1I
1,5	4.0	SD300446F ^[2]	5.3	220	259	201	2I
2,2	5.5	SD300646F ^[2]	5.5	220	259	201	2I
4	9.0	SD300946F ^[2]	5.6	220	259	201	2I
5,5	12	SD301246F ^[2]	8.8	250	328	227	3I
7,5	16	SD301646F ^[2]	8.9	250	328	227	3I
11	24	SD302446F ^[2]	9.6	260	400	245	4I
15	30	SD303046F ^[2]	9.8	260	400	245	4I
18,5	39	SD303946F ^[2]	12.4	300	460	250	5I
22	45	SD304546F ^[2]	12.4	300	460	250	5I

NOTES

[1] Class 2.
[2] Class 3.

SD300 - ACCESORIES

Multiple fieldbus options easy to install and use



Profinet

Modbus TCP

CANopen

Profibus-DP

EtherCAT

Ethernet IP

Conduit KIT

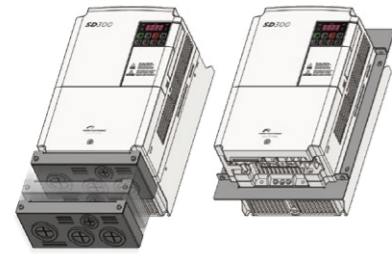

UI Open type and Enclosed type 1 certification:

– UI Open Type is offered as default

– UI Enclosed Type1 needs conduit kit (option) installation

Flange Type.

The heat sink can be mounted outside the panel in case of space limitations.

I/O Expansion card option

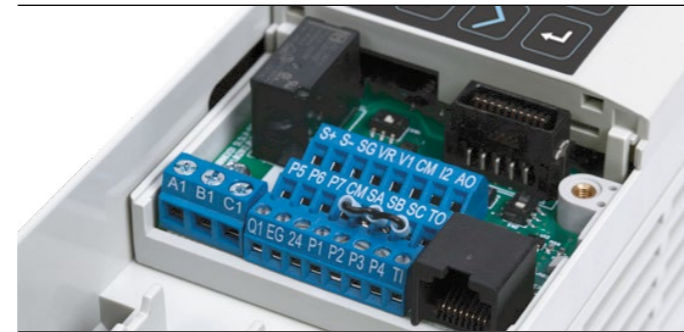

2 Relay outputs

3 Digital inputs

2 Analog Inputs

1 Analog Output

ACCESORIES REFERENCES

REFERENCE	DESCRIPTION
SD3CO	CANopen communications module
SD3PB	Profibus communications module
SD3ETH	Ethernet I/P – Modbus TCP communications module
SD3ETC	EtherCAT communications module
SD3PN	Profinet communications module
SD3IO	Expansion module I/O
SD3EBF1	Conduit module frame 1N and 2N for NEMA1 compliant
SD3EBF2	Conduit module frame 3N and 4N for NEMA1 compliant
SD3EBF3	Conduit module frame 5N for NEMA1 compliant
SD3EBIP6F1	Conduit module frame 1F for NEMA1 compliant
SD3EBIP6F2	Conduit module frame 2F for NEMA1 compliant
SD3EBIP6F3	Conduit module frame 3F for NEMA1 compliant
SD3EBF4	Conduit module frame 4 for NEMA1 compliant
SD3EBF5	Conduit module frame 5 for NEMA1 compliant
SD3EBF6	Conduit module frame 6 for NEMA1 compliant
SD3EBF7	Conduit module frame 7 for NEMA1 compliant
SD3EBF8	Conduit module frame 8 for NEMA1 compliant
SD3EBF9	Conduit module frame 9 for NEMA1 compliant
SD3FLGF1	Flange module frame 1N and 2N
SD3FLGF2	Flange module frame 3N and 4N
SD3FLGF3	Flange module frame 5N
SD3FLGIP6F1	Flange module frame 1F
SD3FLGIP6F2	Flange module frame 2F
SD3FLGIP6F3	Flange module frame 3F
SD3FLGF4	Flange module frame 4
SD3FLGF5	Flange module frame 5
SD3FLGF6	Flange module frame 6
SD3CF2	Remote display-keypad option
SD3CF1	Kit Remote display-keypad option

SD150

The smallest of the family.
Suitable for low power applications.

SD150

Due to its simple operation and compact size is perfect for reduced spaces allowing the integration of multiple units in the same cubicle.

Compact and competitive. Compact and competitive equipment for multiple applications.

Easy installation. Two holes allow the user to screw the unit to a panel mounted in your cabinet. The rear cooling fans can be easily removed from the bottom, a book type design allows the user to install drives side by side saving space, and the front connections reduce wiring complexity.

Multiple I/O. Feature with 1 Analog input, 5 digital inputs, 1 Analog output, 1 digital output and 1 output relay that can be easily programmed to be connected to pressure transducers, level sensors, flow meters, PLCs or external controllers. The digital signals can be easily shifted from NPN to PNP mode with a selector. Modbus RTU integrated.

Single phase applications. Its features cover a wide range of applications in motion drives and HVAC. Treadmills, automatic gates, irrigation pumps, clean water pumps, ornamental fountains and others are a small sample of what you can do with this small and competitive drive.





200 - 230 V

From 0.4 kW to 2.2 kW

Drive three-phase motors with single-phase supply

SD150

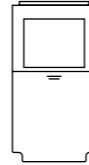

INPUT	Power range	0,4kW - 2,2kW	
	Voltage power	200 to 230Vac (±10%) Monophase	
	Input frequency	50-60Hz (±5%)	
	Input power factor	> 0.98% (over fundamental frequency)	
	Input EMC filter	Class 2 (Integrated)	
	OUTPUT	Motor output voltage	200Vac - 230Vac, Three phase
		Overload capacity	150% during 60 sec. 200% during 30 sec.
		Frequency ratings	0 to ±400Hz
		Efficiency (full load)	>98%
		Modulation method	Vector space modulation
Modulation frequency		Maximum 15kHz	
Output cable length		USC 50m, SC 25m [1]	
Control method		V/Hz control	
Operation method		PID Control. Potentiometer and 3 wires control	
ENVIRONMENTAL CONDITIONS		Degree of protection	IP20
	Operation temperature	-10°C to +50°C	
	Storage temperature	-20°C to +65°C	
	Relative humidity	<90%, non-condensing	
	Altitude	1000m	
	Power altitude derating (> 1000m)	(>1000m)-1% per 100m; maximum 3000m	
	Vibration	Max. 5.9m/sec ² (= 0.6G)	
PROTECTIONS	Drive trip	Over-voltage, Under-voltage, Over-current, Ground fault current detection, Over-temperature of inverter and motor, Output phase open, Overload, Communication error, Loss of frequency command, Hardware fault	
	Alarm condition	Stall prevention, Overload	
INPUTS/ OUTPUTS	Analog inputs	1 input 0-10Vdc / 0-20mA	
	Digital inputs	5 configurable inputs	
	Analog outputs	1 output 0-10Vdc	
	Digital outputs	2 multifunction relay 2A 30Vdc, 0.5A 125Vac	
COMMUNICATIONS	Protocol (Integrated)	Modbus-RTU, RS485	
Regulations		CE, cTick, UL ^[2] , cUL ^[2]	

NOTES [1] For more detailed specifications consult with Power Electronics. [2] On process.

DIMENSIONS (mm)

Frame 1

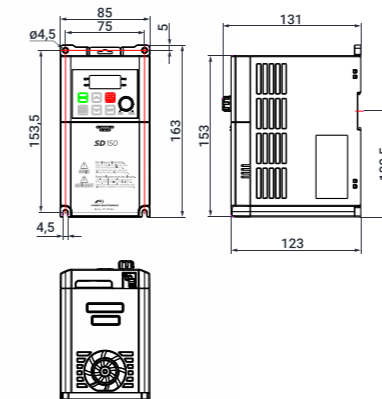

Frame 2

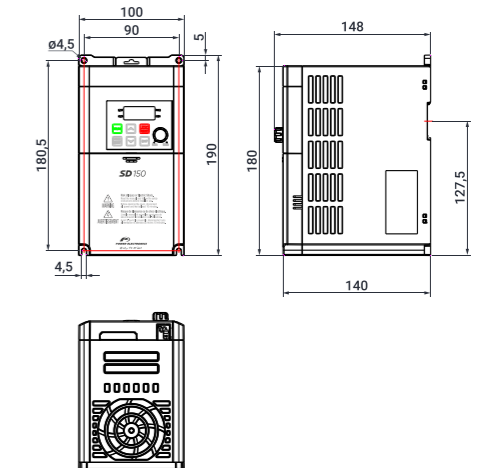

INPUT & OUTPUT WIRING

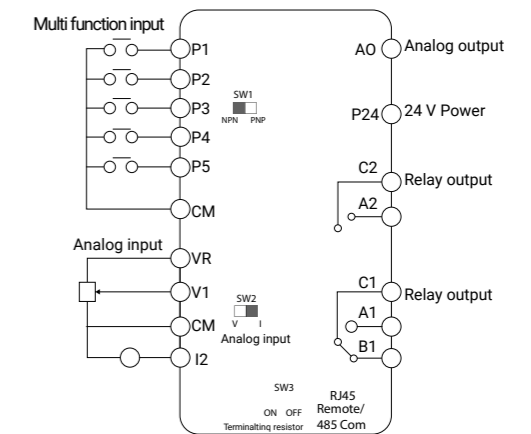
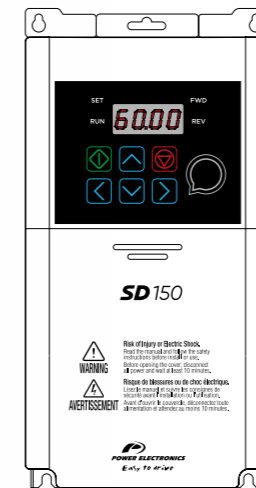

STANDARD RATINGS AND WEIGHTS

Frame	Code	Power (kW)	Current (A)	Voltage Supply (V)	Weight (Kg)
1	SD1503F	0.4	2,4	230 II	1.45
	SD1505F	0.75	4,2	230 II	1.45
2	SD1508F	1.5	7,5	230 II	3.30
	SD1512F	2.2	10	230 II	3.30

NOTES

V6

The V6 is manufactured to the highest standards of quality and mechanical robustness, and is supplied with hardware and software designed for continuous operation with the even most demanding of applications.

V6

User experience. The V6 starter has an intuitive user interface that makes setup and operation easier. The LCD screen displays important information such as engine status, temperature, current... The buttons and menus are easy to understand and use, even for inexperienced users.

Reliability. The V6 starter is equipped with a series of safety features that protect the engine and the starter. These features include overloading protection, overheating protection, short-circuit protection, and ground fault protection, among others. The V6 starter also has a feature to continue working even with a damaged phase if necessary.

Versatility. The V6 starter can be used with a wide range of engines and applications thanks to its wide current range of 16-1250A. It includes functions such as adaptive control, pump cleaning, DC break, reverse direction, etc., to cover the wide range of possibilities for pump control operation.

Communications. Compatible with a multitude of standardized communication protocols to interact with any monitoring and control system: Modbus RTU, Modbus TCP, Profibus, Profinet, Devicenet, and Ethernet/IP.

Efficiency. The entire range of V6 starters includes integrated bypass, meaning the permanent regime efficiency is over 99%. Additionally, the starter offers several start and stop options to maximize efficiency throughout its operation time.

Pumping applications. For pressure control pumping applications, the starter features a SmartPump expansion card that has extra dedicated digital and analog I/O for the application.





200 - 690 V

From 7.5 kW to 1200 kW

V6

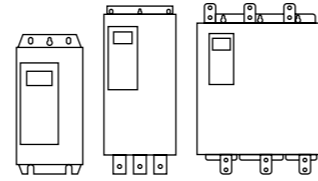

INPUT	Current range ^[1]	16A – 1250A (7.5kW – 1200kW)		
	Voltage range	200 – 525 VAC ($\pm 10\%$) 380 – 690 Vac (-5/+10%)		
	Control voltage	110 - 240 VAC (+10%/-15%), 600mA		
	Input frequency	50Hz/60Hz ($\pm 5\%$)		
OUTPUT	Output voltage	0 to 100% Supply voltage		
	Output frequency	Equal to input		
	Efficiency (At full load)	$\geq 99\%$		
ENVIRONMENTAL CONDITIONS	Operation ambient temperature	Minimum: -10°C Maximum: +60°C ^[2]		
	Storage temperature	Minimum: -25°C Maximum: +60°C		
	Altitude ^[1]	> 1000m, 1% PN(kW) each 100m; 3000m maximum		
	Ambient humidity	< 95%, non-condensing		
	Degree of protection	IP20 (Frame 1) IP00 (Frames 2 y 3) ^[3]		
	Vibration	According IEC 60068-2-6		
	Conformal Coated Electronics	Class 3C3		
PROTECTIONS	Motor protections	Phase sequence		
		Locked rotor		
		Phase imbalance		
		Overload and underload		
		Low power and over power		
		Motor temperature (thermal model)		
		Motor overtemperature (PTC)		
		Excessive starting time		
		Maximum number of starts per hour		
		Softstarter protections	SCR short circuit	
	Ground fault current			
	Heatsink temperature			
	Input phase loss			
	Low input voltage			
	High input voltage			
	Equipment thermal model			
	Ground fault			
	Loss of signal from analog inputs settings functions			
	SETTINGS		Functions	Parameter lock
		Second motor setting		
Scheduled start/stop (days of the week and time)				
DC brake				
Pump cleaning cycle				
Adaptive stop control				
Operation at reduced speed (Jog)				
Operation with a damaged phase (PowerThrough)				
HARDWARE		Digital inputs		2 fixed (Start/Stop and Reset)
				2 programmable

NOTES

- [1] Consult availability with Power Electronics.
 [2] Above 40°C with power reduction.
 [3] Optional IP20 for sizes 2 and 3.

HARDWARE	Digital outputs	2 fixed relays (Main contactor and bypass) 1 configurable switch (NO/NC) 1 configurable relay (NO)
	Analog outputs	1 analog output (0-20mA or 4-20mA)
	Ptc input	Trip > 3.6k Ω , reset < 1.6k Ω
	Expansion slots	1
OPTIONALS ^[4]	Optional hardware	Remote Keypad
		IP20 Conversion Kit (Sizes 2 and 3)
		Disassembly tool (V6TOOL)
		"Pumping Smart Card" board: - 3 digital inputs - 3 analog inputs 4-20mA - 1 RTD input - 1 USB-B port
	Serial communication	DeviceNET
		Modbus RTU ^[5]
		Profibus-DP
	Ethernet communication	Modbus-TCP ^[5]
		Ethernet/IP ^[5]
		Profinet ^[5]
CONTROL PANEL	Type	Fixed
	Length ^[6]	3 meters
	Connectivity	PC software through Modbus RTU, Modbus TCP, or USB.
		LCD display with 4 lines of information
	Lcd display	LED indicators (Ready, Run, Trip, Local)
		Keypad with 4 keys (Menu, Back, Up, Down)
	Remote keypad (opcional)	LCD display with four lines of information
		LED indicators (Ready, Run, Trip, Local)
		Keypad with 11 keys (Start, Stop, Reset, Local/Remote, Menu, Back, Up, Down, Logs, Graph, and Tools)
		Software version
Display information	Current in the three phases	
	Voltage in the three phases and average voltage	
	Mains frequency	
	Motor power factor	
	Motor power	
	Motor temperature (%)	
	Operating hours	
	Number of starts	
	I/O value	
	Heatsink temperature	
REGULATIONS	Certifications	CE, RCM, RoHS, UKCA, WEEE
		Directive EMC (2014/35/EU)
		IEC60947-4-2
		IEC 60068-2-6 – Vibration

NOTES

- [4] All optional cards have a connector for the remote keypad.
 [5] Includes "Ground Fault" for ground fault detection.
 [6] It only affects the remote keypad.

FRAMES

Frame 1

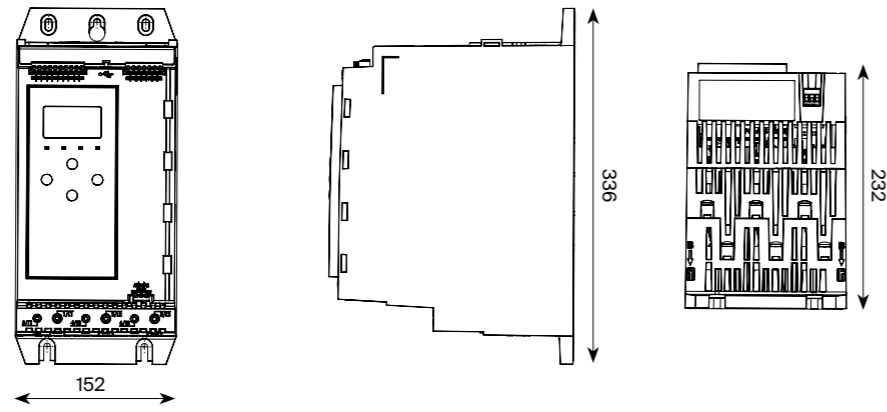

Frame 2A

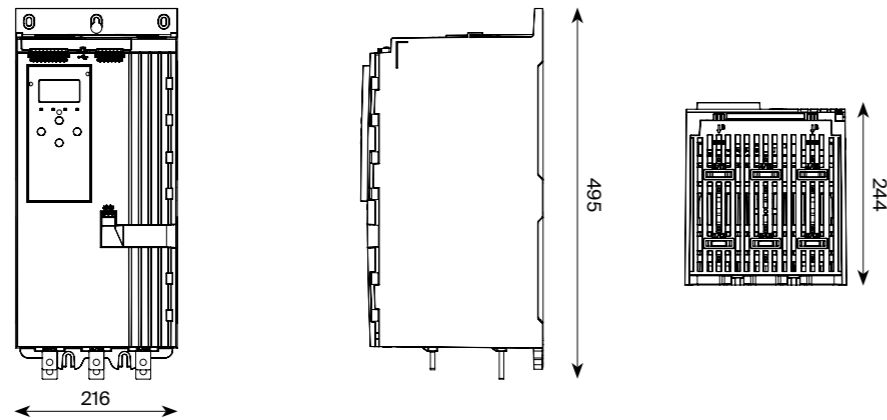

Frame 2B

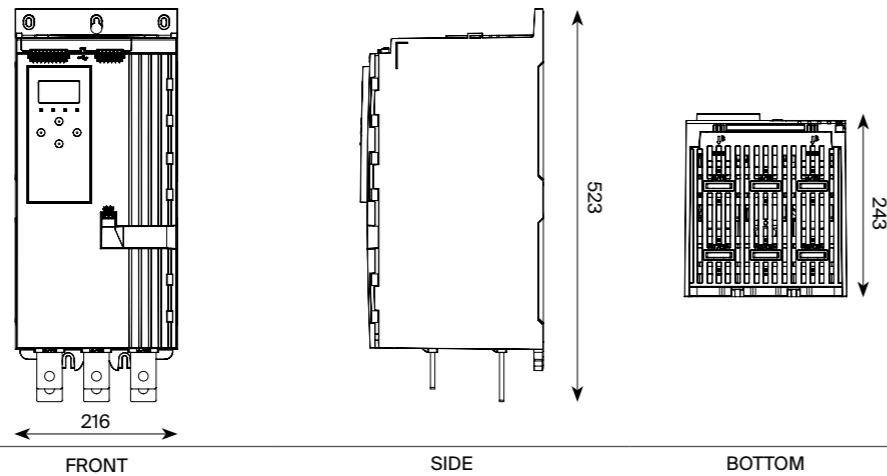

FRONT

SIDE

BOTTOM

FRAMES

Frame 3

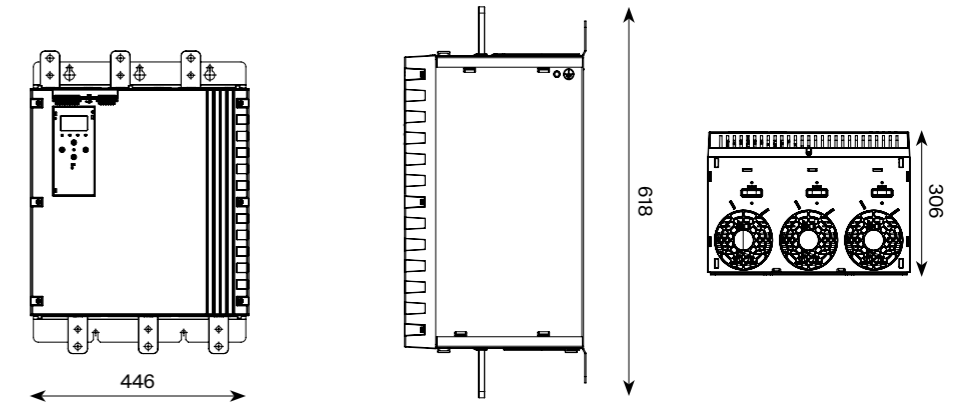

FRONT

SIDE

BOTTOM

V6

CONFIGURATION TABLE

V6 Series	Nominal Current		Input Voltage		Bypass	
V6	24	24A	5	200 - 525 VCA	B	with bypass
	6	380 - 690 VCA		
	1250	1250A				

STANDARD RATINGS

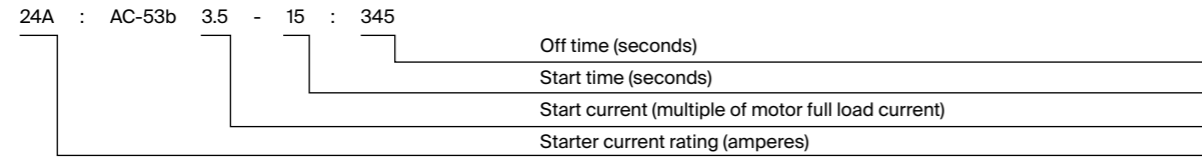

DIRECT CONNECTION

Frame	Model	3.0-10:350	3.5-15:345	4.0-10:350	4.0-20:340	5.0-5:355
1	V60024xB	24A	20A	19A	16A	16A
	V60042xB	42A	34A	34A	27A	31A
	V60052xB	52A	41A	39A	34A	34A
	Model	3.0-10:390	3.5-15:585	4.0-10:590	4.0-20:580	5.0-5:595
	V60064xB	64A	62A	60A	50A	53A
	V60105xB	105A	86A	84A	68A	76A
	V60115xB	115A	107A	104A	86A	95A
2	V60135xB	135A	129A	126A	103A	115A
	V60200xB	200A	170A	165A	138A	150A
	V60229xB	229A	194A	187A	157A	170A
	V60250xB	250A	244A	230A	200A	202A
	V60352xB	352A	285A	277A	234A	257A
	V60410xB	410A	410A	410A	379A	400A
3	V60550xB	550A	526A	505A	427A	462A
	V60835xB	835A	654A	630A	535A	592A
	V61070xB	1070A	950A	905A	785A	834A
	V61230xB	1230A	1154A	1090A	959A	989A
	V61250xB	1250A	1250A	1250A	1155A	1250A

NOTES

INTERNAL TRIANGLE

Frame	Model	3.0-10:350	3.5-15:345	4.0-10:350	4.0-20:340	5.0-5:355
1	V60024xB	36A	30A	29A	24A	24A
	V60042xB	63A	51A	51A	41A	47A
	V60052xB	78A	62A	59A	51A	51A
	Model	3.0-10:390	3.5-15:585	4.0-10:590	4.0-20:580	5.0-5:595
	V60064xB	96A	93A	90A	75A	80A
	V60105xB	158A	159A	126A	102A	114A
	V60115xB	173A	161A	156A	129A	143A
2	V60135xB	203A	194A	189A	155A	173A
	V60200xB	300A	255A	248A	207A	225A
	V60229xB	344A	291A	281A	236A	255A
	V60250xB	375A	366A	345A	300A	303A
	V60352xB	528A	428A	415A	351A	386A
	V60410xB	615A	615A	615A	568A	600A
3	V60550xB	825A	789A	758A	640A	694A
	V60835xB	1253A	981A	945A	803A	888A
	V61070xB	1605A	1425A	1358A	1178A	1251A
	V61230xB	1845A	1731A	1635A	1439A	1484A
	V61250xB	1875A	1875A	1875A	1733A	1875A

ACCESSORIES

CODE	DESCRIPTION
V6DN	DeviceNet communications module
V6ET	Ethernet I/P + Ground Fault communications module
V6FG1	Fingerguard, Frame 2
V6FG2	Fingerguard, Frame 3
V6TCP	Modbus TCP + Ground Fault communications module
V6RTU	Modbus RTU + Ground Fault communications module
V6PB	Profibus communications module
V6PN	Profinet + Ground Fault communications module
V6CF1	Remote Keypad Card
V6CF3	Remote, Keypad Card + Keypad
V6CF2	Remote Keypad
V6PUMP	Pumping Smart Card, Pump Applicaton
V6TOOL	Enclosure Opening Tools

NOTES

FQP

&

FQQA

Designed to cancel out harmonics.

FQP

The FQP Freemaq harmonic filter is installed at the entrance of the drive and is designed for both drives SD750 range of Power Electronics as other commercial inverters.

With a more compact and efficient design, Freemaq FQP provides a higher degree harmonics filtering through more stable tuning that provides values THDi below 5% in compliance with IEEE519.

Its construction is based on the **installation of one or more filter modules in parallel** which will be controlled and protected at all times by the drive.





Reliable and robust
electronics conformally
coated (IP54)

Power range from 2,2kW
to 110kW

Reduction of the THDI
< 5% IEEE519

Automatic protection

FQP



400 Vac					
CODE	POWER kW	HEIGHT mm (H)	WIDTH mm (W)	DEPTH mm (D)	WEIGHT (kg)
FQP0006 5	2,2				
FQP0009 5	4				
FQP0012 5	5,5	508	207	279	50
FQP0018 5	7,5				
FQP0024 5	11				
FQP0032 5	15				
FQP0038 5	18,5	851	500	394	75
FQP0048 5	22				
FQP0060 5	30				
FQP0075 5	37				
FQP0090 5	45	990	500	395	110
FQP0115 5	55				
FQP0150 5	75				
FQP0170 5	90	1207	608	440	180
FQP0210 5	110	2000	407	529	285

NOTES

FQA

The active harmonic filter FQA injects reactive power and current in the form of harmonics designed to improve the power factor ($\cos \varphi$) and cancel harmonic distortion (THDi), helping to stabilize the network voltage of the electrical distribution system.

Electronic components totally sealed to **IP54** standards, without dust filters.

Dynamic control of voltage to stabilize the network.

Dynamic and precise cancelling of harmonics.





Operation up to 50°
From 380 Vac to 525 Vac

FQA

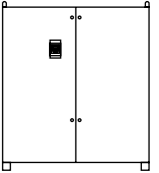

STANDARD RATINGS 400 Vac

FRAME	MODEL	Total RMS Current Limit (A) (400V)		Max. Individual Harmonic Compensation (A)			
		Total RMS Current (A) 40°C	Total RMS Current (A) 50°C	I5 (80%)	I7 (50%)	I11(30%)	I13 (15%)
5	FQA0100 5X	100	90	80	50	30	15
	FQA0150 5X	150	135	120	75	45	23
	FQA0200 5X	200	180	160	100	60	30
6	FQA0250 5X	250	225	200	125	75	38
	FQA0315 5X	315	284	252	158	95	47
	FQA0400 5X	400	360	320	200	120	60
7	FQA0450 5X	450	405	360	225	135	68
	FQA0500 5X	500	450	400	250	150	75
	FQA0600 5X	600	540	480	300	180	90
8	FQA0700 5X	700	630	560	350	210	105
	FQA0800 5X	800	720	640	400	240	120

STANDARD RATINGS 480 Vac A 525 Vac

FRAME	MODEL	Total RMS Current Limit (A) (400V)		Max. Individual Harmonic Compensation (A)			
		Total RMS Current (A) 40°C	Total RMS Current (A) 50°C	I5 (80%)	I7 (50%)	I11(30%)	I13 (15%)
5	FQA0100 7X	100	90	80	50	30	15
	FQA0165 7X	165	149	132	83	50	25
6	FQA0200 7X	200	180	160	100	60	30
	FQA0250 7X	250	225	200	125	75	38
	FQA0330 7X	330	297	264	165	99	50
7	FQA0400 7X	400	360	320	200	120	60
	FQA0450 7X	450	405	360	225	135	68
	FQA0495 7X	495	446	396	248	149	74
8	FQA0600 7X	600	540	480	300	180	90
	FQA0660 7X	660	594	528	330	198	99

NOTES

Power ON Support

Our secret. The key of our success for more than 35 years, our 24/7 after sales service, Power On Support.

We take care of the legacy

generations. Each new generation of **electronic soft starters and variable speed drives** involves adapting the manufacturing lines to optimize the production of these new units. Power Electronics has optimized facilities for the production of previous generation units, where we manufacture ongoing subcomponents adapted to equipment that is no longer in production, allowing an extended life.

Long Term Service. We repair subcomponents or even manufacture equivalent units in our Dedicated Service Factory located near our Production Plant. Power Electronics has experience in repowering old photovoltaic plants, where we supply state-of-the-art equipment adapting its electrical characteristics to be compatible with the existing configuration, while providing all the advantages of the latest generation **electronic soft starters and variable speed drives.**



We are here
to help you

Vertical Integration throughout the entire process.

The vertical integration is one of our key values. We look after the entire value chain, from design to the on-site commissioning of the products, ensuring the accurate development of all the power electronics inside our **electronic soft starters and variable speed drives.**

BEFORE COMMISSIONING

- Technical application & design requirement review.
- Dedicated Project Management Support.
- Hands on functional & safety product training.

DURING COMMISSIONING

- Dedicated commissioning teams.
- Rigorous execution through site operation.

AFTER COMMISSIONING

- Support 24/7, 365 days a year.
- Full warranty coverage with options for extension and full preventative maintenance packages.
- Advanced remote monitoring, detailed performance reporting, and interactive portals for tracking metrics directly with Power Electronics.

HEADQUARTERS**SPAIN**

Polígono Industrial Carrases
Ronda del Camp d'Aviació, 4
46160 Llíria, Valencia (Spain)
Cell. (+34) 96 136 65 57
Fax (+34) 96 131 82 01
24/7 Technical Assistance Service
Phone. (+34) 902 40 20 70

UNITED STATES

1510 N. Hobson Street, Gilbert
Arizona, USA
Cell. (+001) 602-354-4890
sales@power-electronics.us
24/7 Technical Assistance Service

INTERNATIONAL**ARGENTINA**

Arroyo 894, 5°
Oficina 10, Ciudad autónoma
de Buenos Aires.

ASIA

30th Floor, CATIC Plaza, 8 Causeway
Road, Hong Kong SAR

AUSTRALIA

U6, 30-34 Octal St. Yatala, Brisbane,
Queensland 4118.
(+61) 7 3386 1993
sales@power-electronics.com.au

BEIJING

Xiaoying Road Chaoyang, N°25,
Beijing City.

BRAZIL

Avda. Robert Kennedy 2070. Sao
Bernardo do Campo. Sao Paulo.
(+55) 11 5891 9612 / (+55) 11 5891 9762
brasil@power-electronics.com

CHILE

Av. Alonso de Córdova 5870, Of. 210-211
Las Condes, Santiago de Chile.
(+56) 2 3223 8916
ventaschile@power-electronics.com

COLOMBIA

Cl 77 9-20 Bogotá DC.
(+57) 322 3464855
colombia@power-electronics.com

DOMINICAN REPUBLIC

Ave. John F. Kennedy Núm. 7,
Los Jardines, Distrito Nacional,
Santo Domingo.

FRANCE

51 Rue Hoche, 94200 Ivry Sur Seine, Paris.
+33(0)1 46 46 10 34
ventesfrance@power-electronics.com

GERMANY

Neuseser Strasse 15, Nürnberg.
germany@power-electronics.com

INDIA

Silver Jade, Off. No 03, G.F., A-Wing
CTS NO. -188, Behind Tarun Bharat
Society, Chakala, Andheri East, Mumbai,
Maharashtra
(+91) 80 6569 0489
india@power-electronics.com

IRELAND

20 Harcourt Street, D02 H364, Dublin.

ITALY

Piazzale Cadorna, 6, 20123, Milano.
italy@power-electronics.com

JAPAN

Nishi-Shinbasi 2-17-2 HF Toranomom Bldg
5F. 105-0003 Minato-Ku Tokio.
japan@power-electronics.com

MALAYSIA

Level 7, Menara Milenium, Jalan
Damanlela, Pusat Bandar Damansara,
Damansara Heights, 50490
Kuala Lumpur W.P.
malaysia@power-electronics.com

MEXICO

Henry Ford n.3, Fraccionamiento
Industrial San Nicolás, Tlalnepantla,
Estado de México.
(+52) 1 5510529888 / (+52) 53908818
mexico@power-electronics.com

NEW ZEALAND

14B Opawa Road, Christchurch 8023.
(+64) 3 379 9826
sales@power-electronics.co.nz

PERU

Avenida El Polo n° 670, Centro Comercial
El Polo II - Oficina 603, Piso 6°, Bloque C
Santiago de Surco, Lima.
(+51) 979 749 772
ventasperu@power-electronics.com

PHILIPPINES

Unit 209 ZF Page 1 Bldg MBP
Ayala Alabang, Muntinlupa.

SOUTH AFRICA

Central Office Park Unit 5
257 Jean Avenue - Centurion 0157.
southafrica@power-electronics.com

UNITED KINGDOM

Chippenham Drive, Unit 2, Madingley
Court. Kingston, Milton Keynes.
MK10 0BZ.
uksales@power-electronics.com

NOTES

WARRANTY

Power Electronics (the Seller) warrants that their Products are free of faults and defects for a period of 3 years, valid from the date of delivery to the Buyer. It shall be understood that a product is free of faults and defects when its condition and performance is in compliance with its specification.

The warranty shall not extend to any Products whose defects are due to (i) careless or improper use, (ii) failure to observe the Seller's instructions regarding the transport, installation, functioning, maintenance and the storage of the Products, (iii) repairs or modifications made by the Buyer or third party without prior written authorization of the Seller, (iv) negligence during the implementation of authorized repairs or modifications, (v) if serial numbers are modified or illegible, (vi) anomalies caused by, or connected to, the elements coupled directly by the Buyer or by the final customer, (vii) accidents or events that place the Product outside its storage and operational specification, (viii) continued use of the Products after identification of a fault or defect.

The warranty excludes components that must be replaced periodically such as fuses, lamps & air filters or consumable materials subject to normal wear and tear.

The warranty excludes external parts that are not manufactured by the Seller under the brand of Power Electronics.

The Seller undertakes to replace or to repair, himself, at their discretion, any Product or its part that demonstrates a fault or defect, which is in conformance with the aforementioned terms of the warranty. Reasonable costs associated with the disassembly/ assembly, transport and customs of equipment will also be undertaken by the Seller except in cases of approved intervention Mby the Buyer and/or their representative where cost allocation has been previously agreed.



Power Electronics reserves the right to modify whole or part of the content of this brochure at any time and without prior notice.

